

PYD

ELECTROBOMBAS

ELECTROBOMBA CENTRÍFUGA MULTICELULAR SERIE SH



GAMA DOMÉSTICA > SERIE SH
DOMESTIC PUMPS • POMPES DOMESTIQUES

COMPLETA EN INOX
MADE ENTIRELY OF STAINLESS STEEL • ENTIÈREMENT EN INOX



SERIE SH

Bombas centrífugas multi-celulares horizontales, para trabajar con aguas limpias en aplicaciones domésticas, riego y conjuntos hidroneumáticos de presión, completamente silenciosas.

Horizontal multistage centrifugal pumps to work with clean water in domestic applications, irrigation and hydropneumatic sets. Totally silent.

Pompes centrifuges multi-cellulaires horizontales de travailler avec de l'eau propre dans les applications domestiques, l'irrigation et ensembles hydropneumatiques. Totalement silencieux.

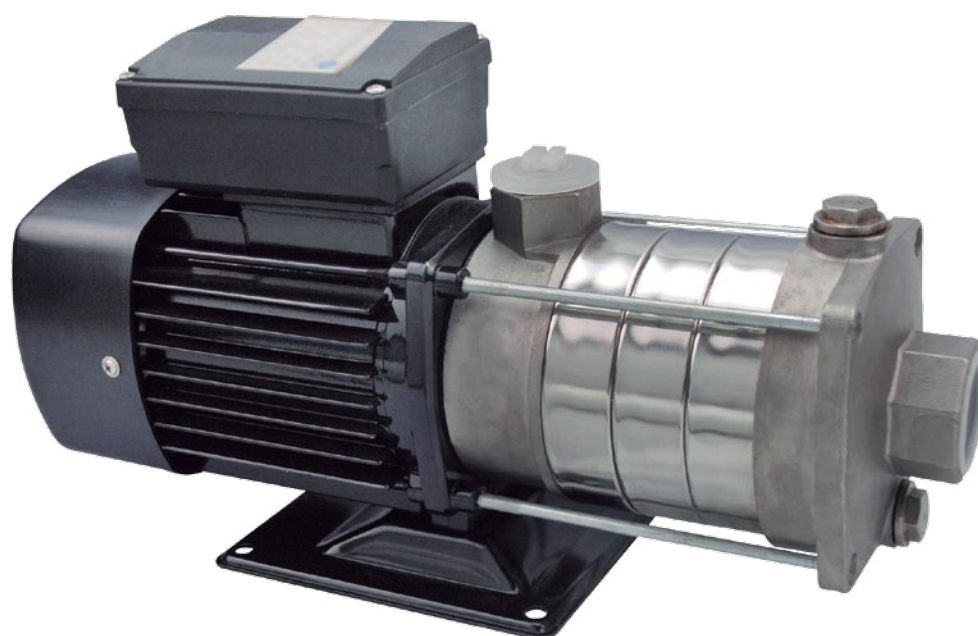

Materiales

Cuerpo aspiración	INOX 304
Cuerpo impulsión	INOX 304
Impulsor	INOX 304
Difusor	INOX 304
Eje rotor	INOX 304
Soporte motor	Fundición
Cierre mecánico	Cer/graf.
Tapa ventilador	Aluminio
Tornillería	INOX 304

Rango de trabajo

Protección	IP 55
Aislamiento	Clase F
Temperatura	15° - 70°C
Presión máxima	1.0 Mpa
Fluidos	Agua limpia

Materials

Inlet body	SS 304
Outlet body	SS 304
Impeller	SS 304
Diffuser	SS 304
Rotor shaft	SS 304
Motor support	Cast iron
Mechanical seal	Cer/graph.
Fan cover	Aluminum
Screws	SS 304

Working range

Protection	IP 55
Isolation	Class F
Temperature	15° - 70°C
Max. pressure	1.0 Mpa
Fluids	Clean water

Matériels

Corps d'aspir.	INOX 304
Corps d'impuls.	INOX 304
Roue	INOX 304
Diffuseur	INOX 304
Arbre	INOX 304
Support moteur	Fonte
Garniture méc.	Cer/graph.
Couverture	Aluminium
Vis	INOX 304

Plage de travail

Protection	IP 55
Isolement	Class F
Température	15° - 70°C
Pression max	1.0 Mpa
Fluides	Eau propre

Datos técnicos y puntos de servicios

MODELO	DN (Ø")		POTENCIA		PESO	m³/h l/min	1,0	1,5	2,0	2,5	3,0	3,5
	ASP.	IMP.	KW	HP	Kg		17	25	33	42	50	58
SH 2-40	1	1	0,55	0,75	9	m.c.a.	35	32	28	26	23	17
SH 2-50	1	1	0,55	0,75	10		43	40	35	33	28	22
SH 2-60	1	1	0,75	1,0	11		50	48	42	38	32	25

MODELO	DN (Ø")		POTENCIA		PESO	m³/h l/min	2	3	4	5	6	7
	ASP.	IMP.	KW	HP	Kg		33	50	67	83	100	117
SH 4-40	1 ¼	1	0,75	1,0	11	m.c.a.	37	36	34	30	26	20
SH 4-50	1 ¼	1	1,0	1,35	12		45	44	40	36	31	24
SH 4-60	1 ¼	1	1,1	1,5	13		55	53	50	45	38	30

MODELO	DN (Ø")		POTENCIA		PESO	m³/h l/min	4	5	6	7	8	9	10
	ASP.	IMP.	KW	HP	Kg		67	83	100	117	133	150	167
SH 8-20	1 ½	1 ½	1,0	1,35	18	m.c.a.	32	29	27	25	24	21	17
SH 8-25	1 ½	1 ½	1,5	2,0	20		43	37	34	30	27	24	20
SH 8-30	1 ½	1 ½	1,85	2,5	25		44	42	38	36	30	27	24
SH 8-35	1 ½	1 ½	2,2	3,0	26		56	51	48	44	37	32	28
SH 8-40	1 ½	1 ½	2,2	3,0	28		65	57,5	57	50	48	42	34

MODELO	DN (Ø")		POTENCIA		PESO	m³/h l/min	6	7	8	9	10	11	12	13	14
	ASP.	IMP.	KW	HP	Kg		100	117	133	150	167	183	200	217	233
SH 12-20	1 ½	1 ½	1,85	2,5	24	m.c.a.	38	36	35	32	31	29	28	24	20
SH 12-25	1 ½	1 ½	2,2	3,0	26		47	45	43	41,5	39	36	33,5	30,5	27
SH 12-30	1 ½	1 ½	3,0	4,0	28		53,5	52	50	47,5	45	42	39	35	30

MODELO	DN (Ø")		POTENCIA		PESO	m³/h l/min	8	10	12	14	16	18	20	22	24
	ASP.	IMP.	KW	HP	Kg		133	167	200	233	267	300	333	367	400
SH 16-30	2	2	2,2	3,0	26	m.c.a.	38	36	34	33	30	28	26	23	20
SH 16-40	2	2	3,0	4,0	29		50	48	46	44	43	38	36	32	28

MODELO	DN (Ø")		POTENCIA		PESO	m³/h l/min	10	12	14	16	18	20	22	24	26	28
	ASP.	IMP.	KW	HP	Kg		167	200	233	267	300	333	367	400	433	467
SH 20-30	2	2	3,0	4,0	29	m.c.a.	39	38	36	35	33	31,5	30	27	24	21
SH 20-40	2	2	4,0	5,5	34		50	48	46	44	42	40	36	32	28	24

Curvas SH2

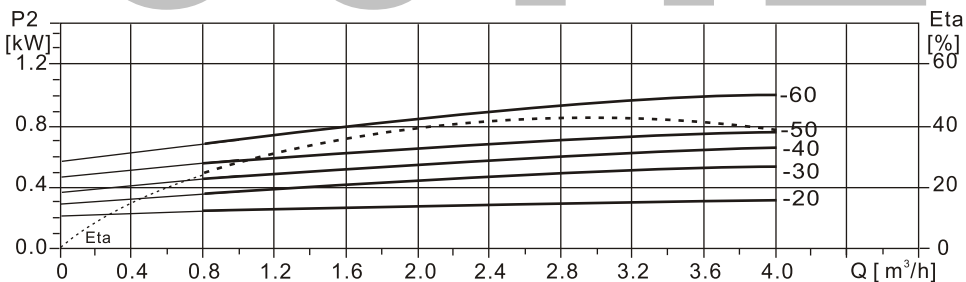
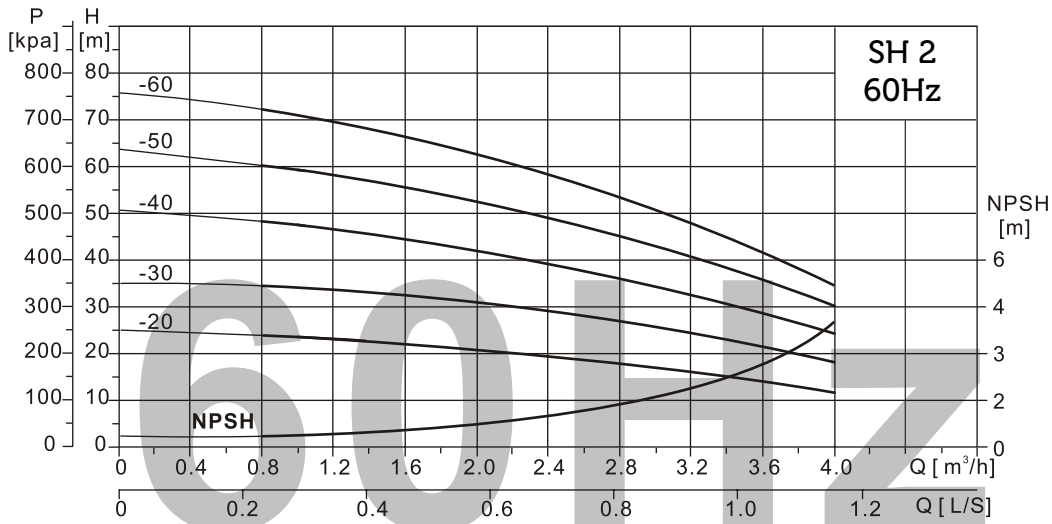
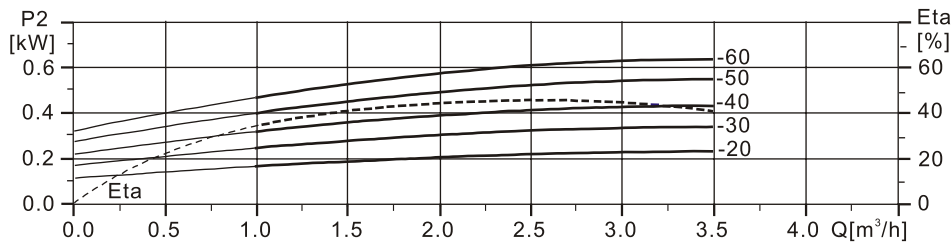
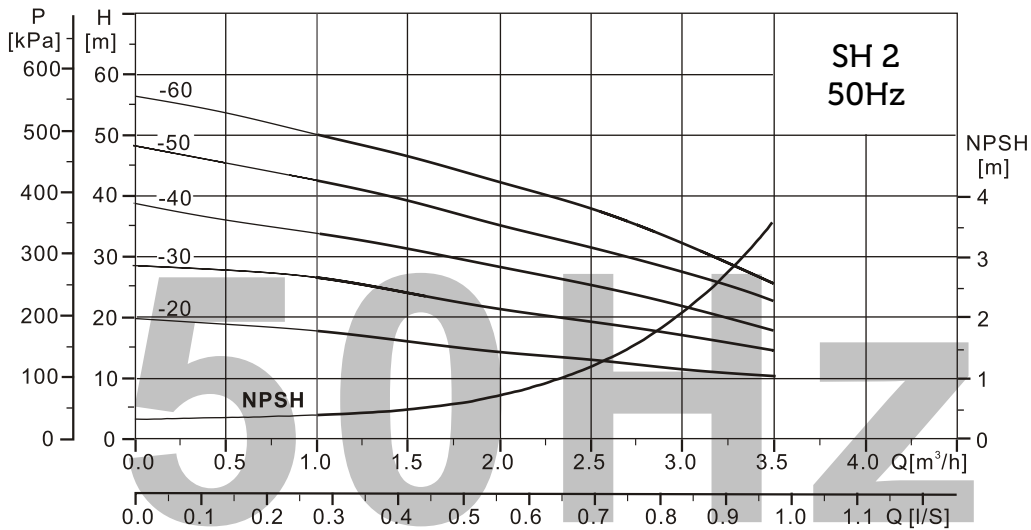

Curvas SH 4

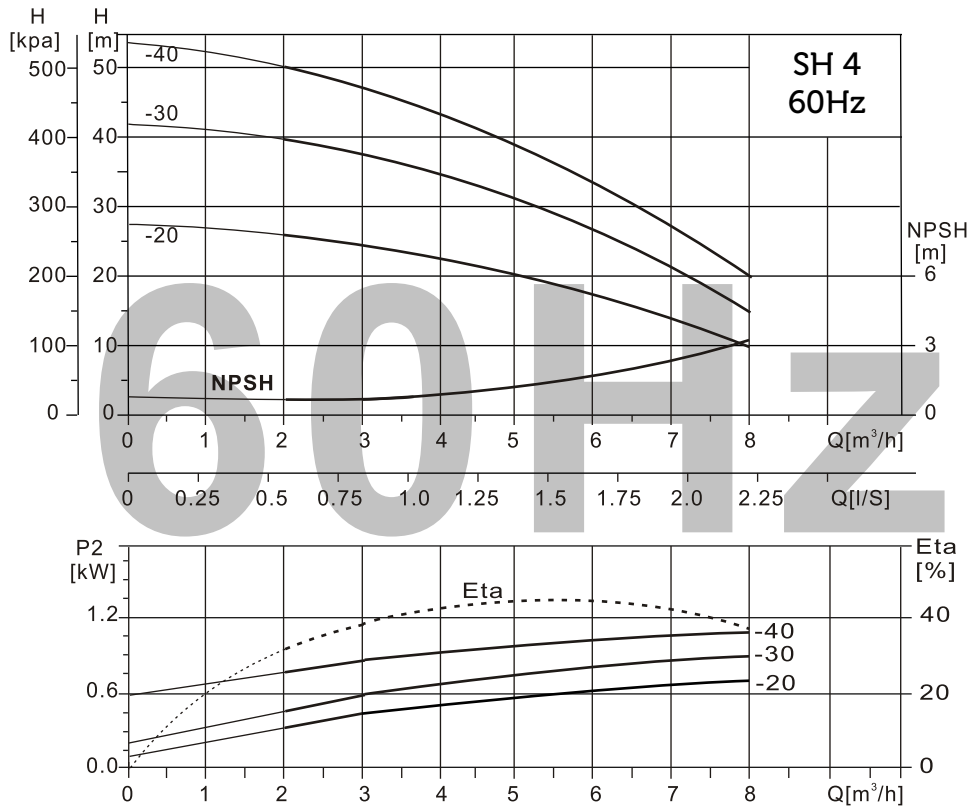
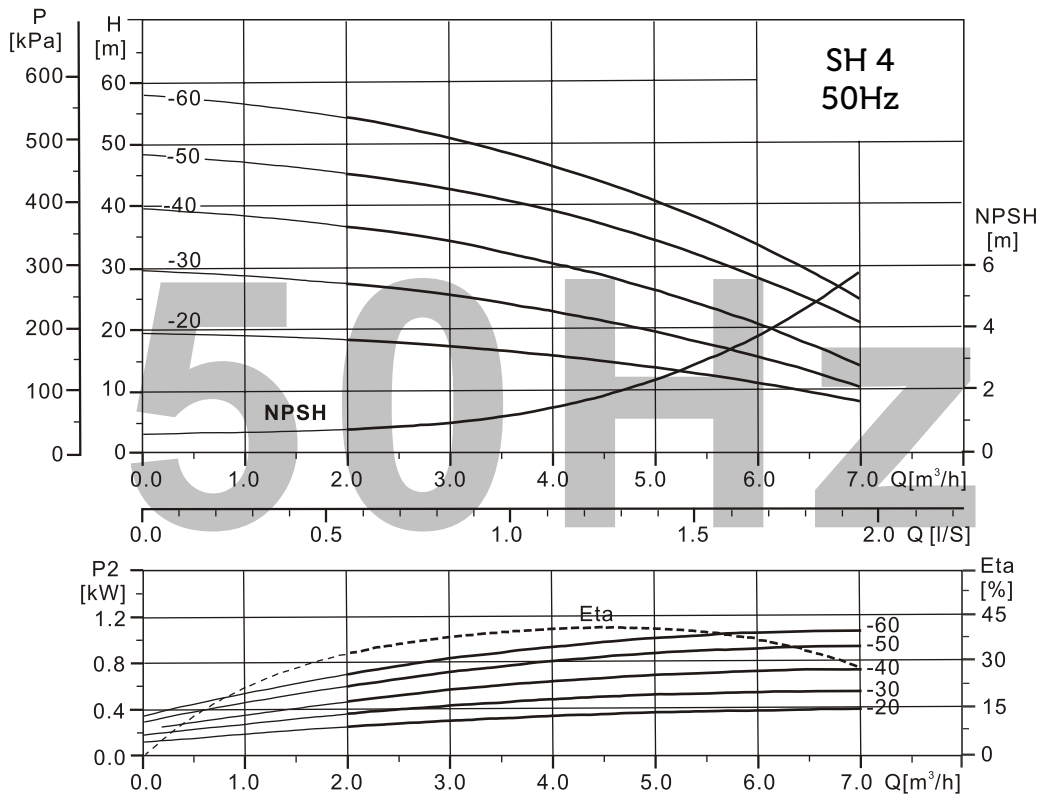

Curvas SH 8

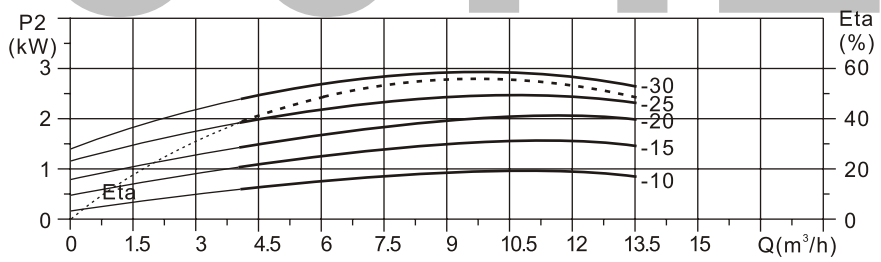
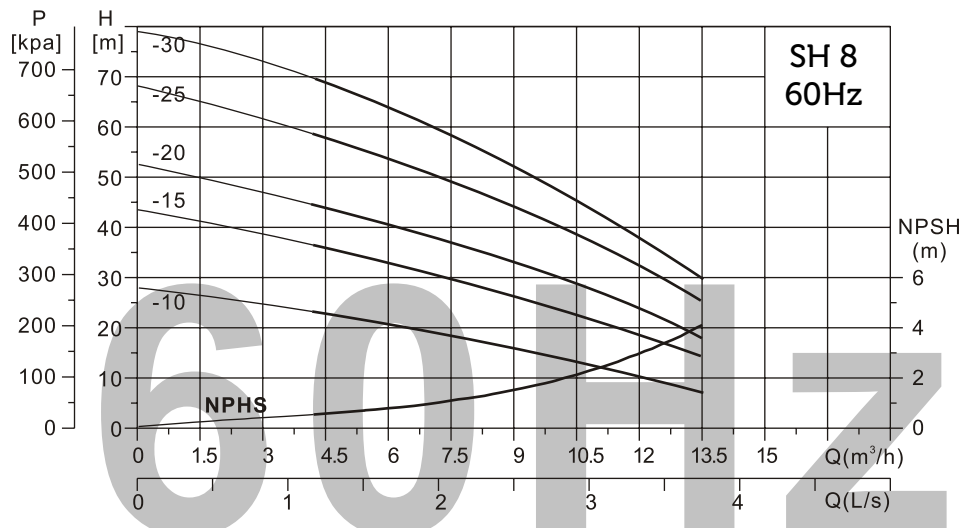
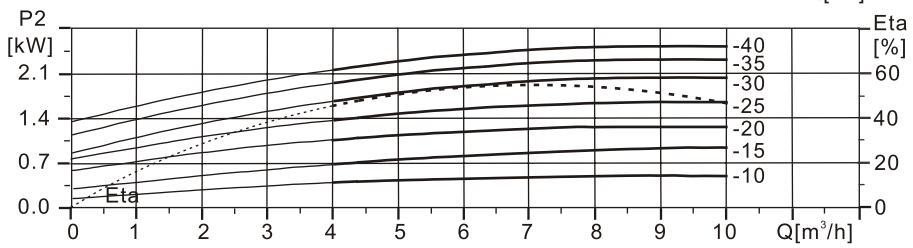
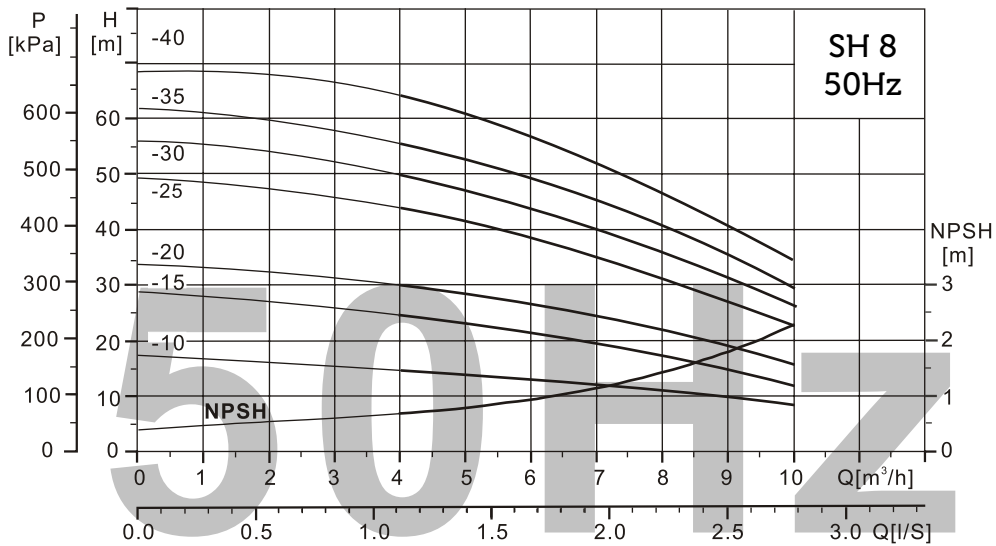

Curvas SH 12

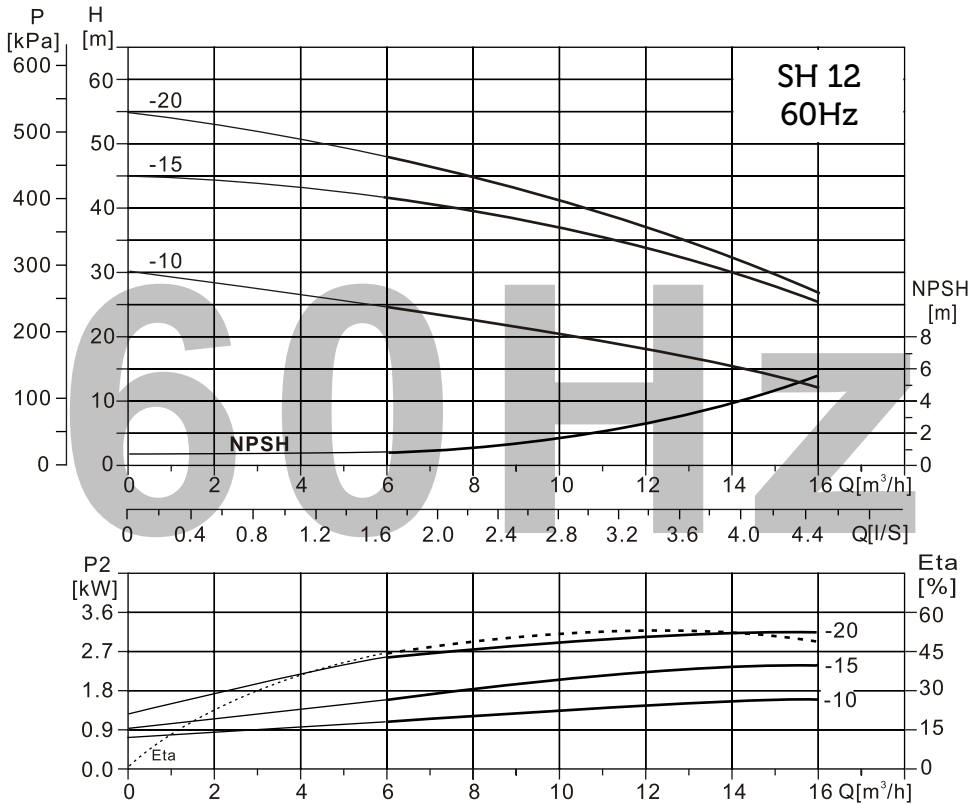
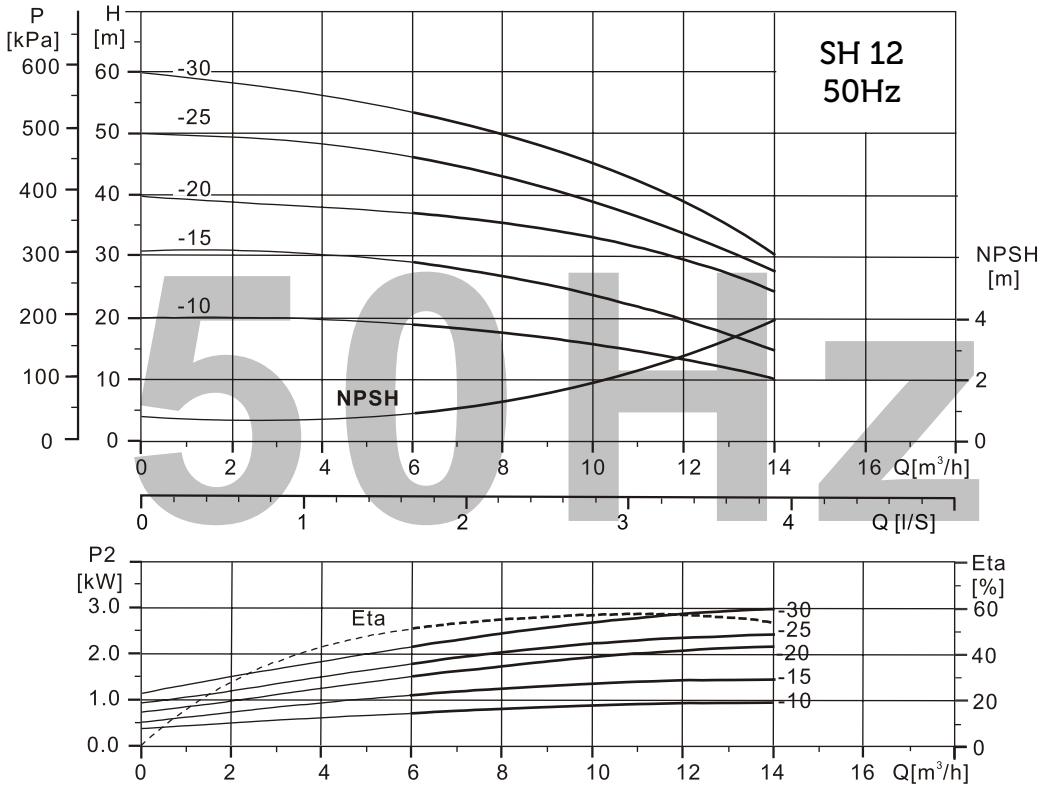

Curvas SH 16

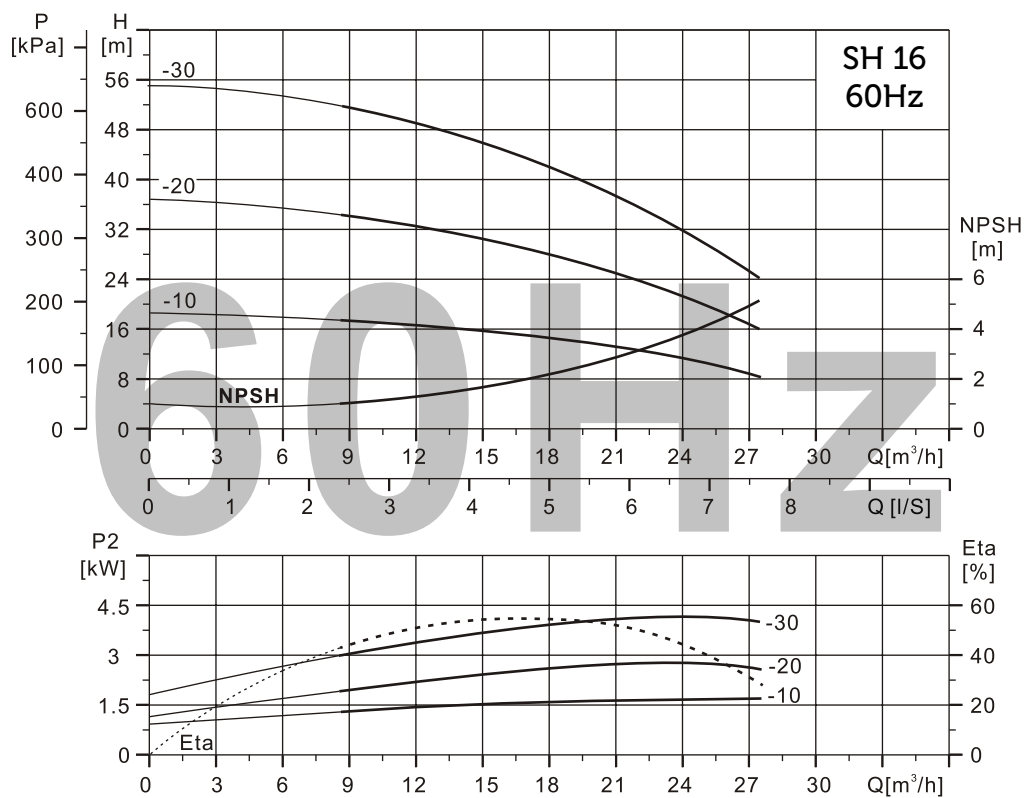
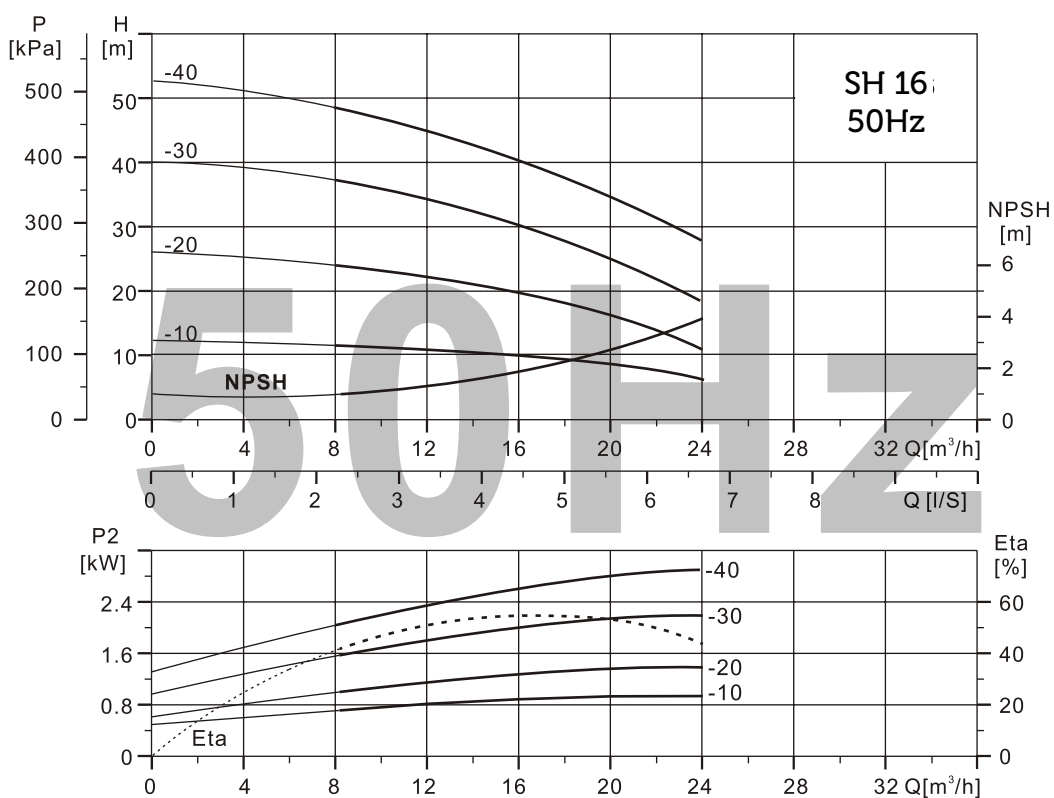

Curvas SH 20

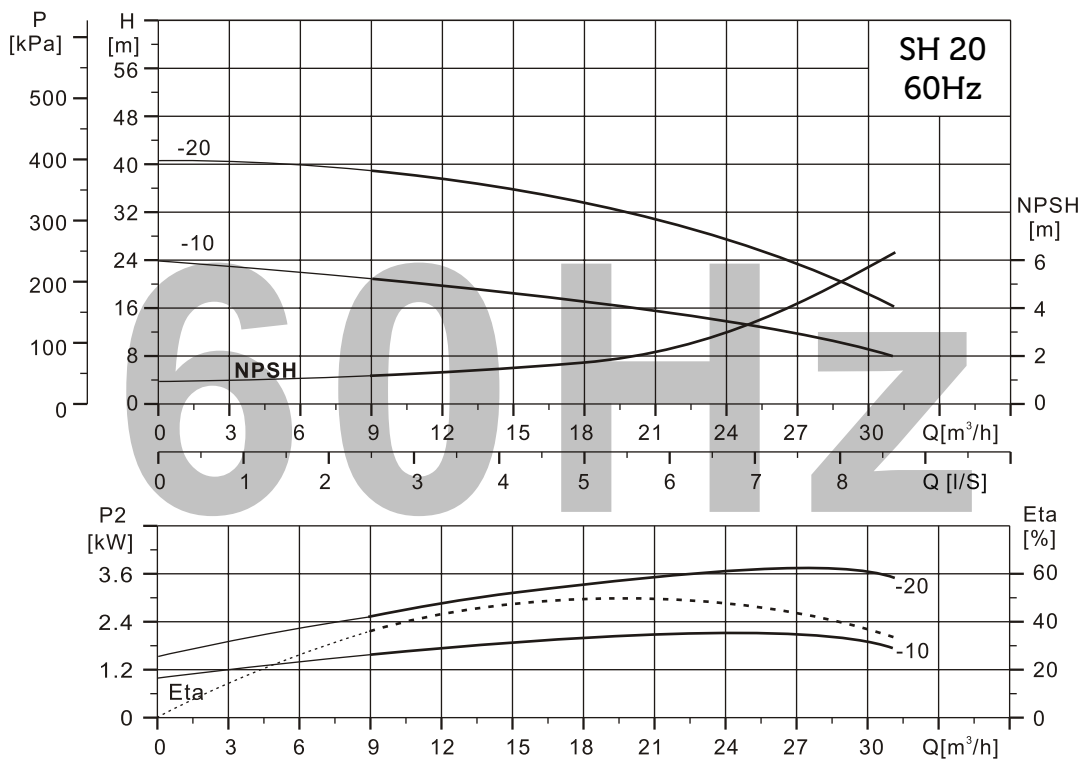
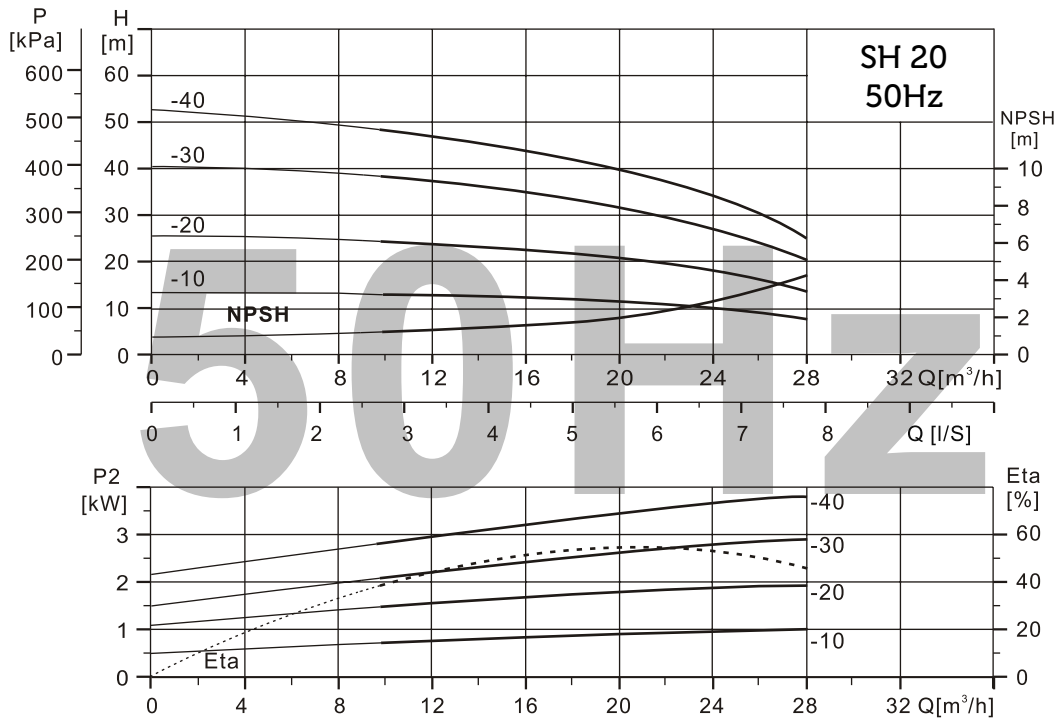

MEDIDAS

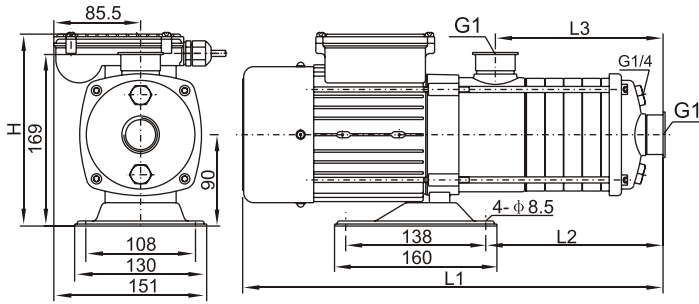

Model	Dimensions(mm)								Weight (kg)
	Single Phase				Three Phase				
	L1	L2	L3	H	L1	L2	L3	H	
SH2-20(T)	342	103	92	189	342	103	92	192	7.5
SH2-30(T)	360	121	110	189	360	121	110	192	8
SH2-40(T)	378	139	128	189	378	139	128	192	9
SH2-50(T)	396	157	146	189	396	157	146	192	10
SH2-60(T)	414	175	164	189	414	175	164	192	11

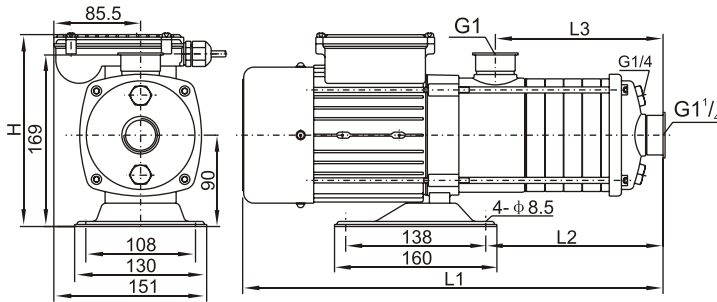

Model	Dimensions(mm)								Weight (kg)
	Single Phase				Three Phase				
	L1	L2	L3	H	L1	L2	L3	H	
SH4-40(T)	378	139	128	189	378	139	128	192	11
SH4-50(T)	396	157	146	215	396	157	146	192	12
SH4-60(T)	414	175	164	215	414	175	164	192	13

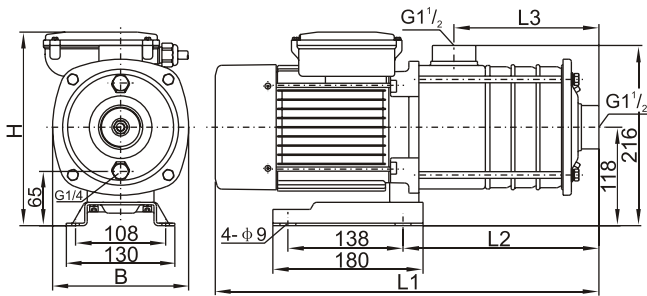

Model	Dimensions(mm)											Weight (kg)
	Single Phase						Three Phase					
	L1	L2	L3	H	B	L1	L2	L3	H	B		
SH8-20(T)	370	175	113	227	163	370	175	113	220	163	18	
SH8-25(T)	432	205	144	235	163	432	205	144	225	163	20	
SH8-30(T)	474	205	144	262	168	432	205	144	225	163	25	
SH8-35(T)	504	235	174	262	168	463	235	174	225	163	26	
SH8-40(T)	504	235	174	262	168	463	235	174	225	163	28	

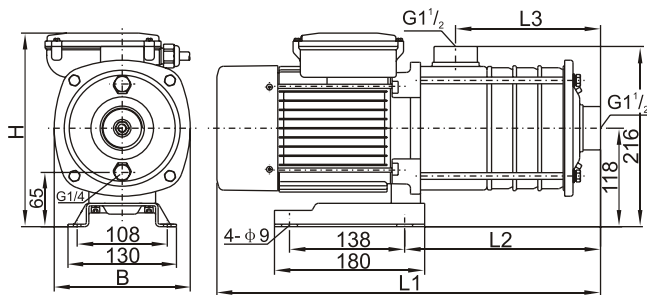

Model	Dimensions(mm)											Weight (kg)
	Single Phase						Three Phase					
	L1	L2	L3	H	B	L1	L2	L3	H	B		
SH12-20(T)	444	175	113	262	168	444	175	113	225	163	24	
SH12-25(T)	474	205	144	262	168	474	205	144	225	163	26	
SH12-30T	-	-	-	-	-	494	205	144	230	168	28	

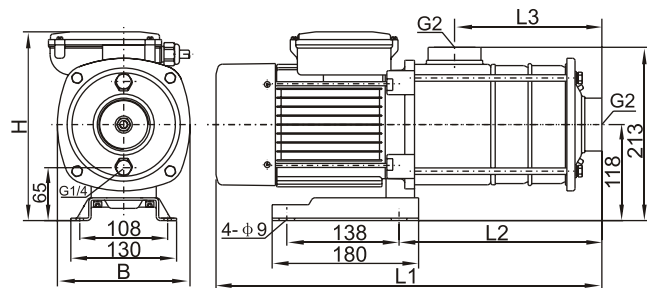

Model	Dimensions(mm)											Weight (kg)
	Single Phase						Three Phase					
	L1	L2	L3	H	B	L1	L2	L3	H	B		
SH16-30(T)	518	249	181	262	168	518	249	181	230	168	26	
SH16-40T	-	-	-	-	-	563	294	226	230	168	29	

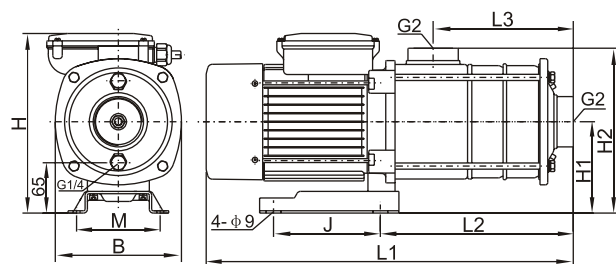

Model	Dimensions(mm)											Weight (kg)	
	Single Phase						Three Phase						
	L2	L3	M	J	H1	H2	H	L1	B	H	L1		B
CUC20-30T	249	181	108	138	118	213	-	-	-	230	538	168	29
CUC20-40T	338	226	190	140	132	227	-	-	-	279	602	190	34

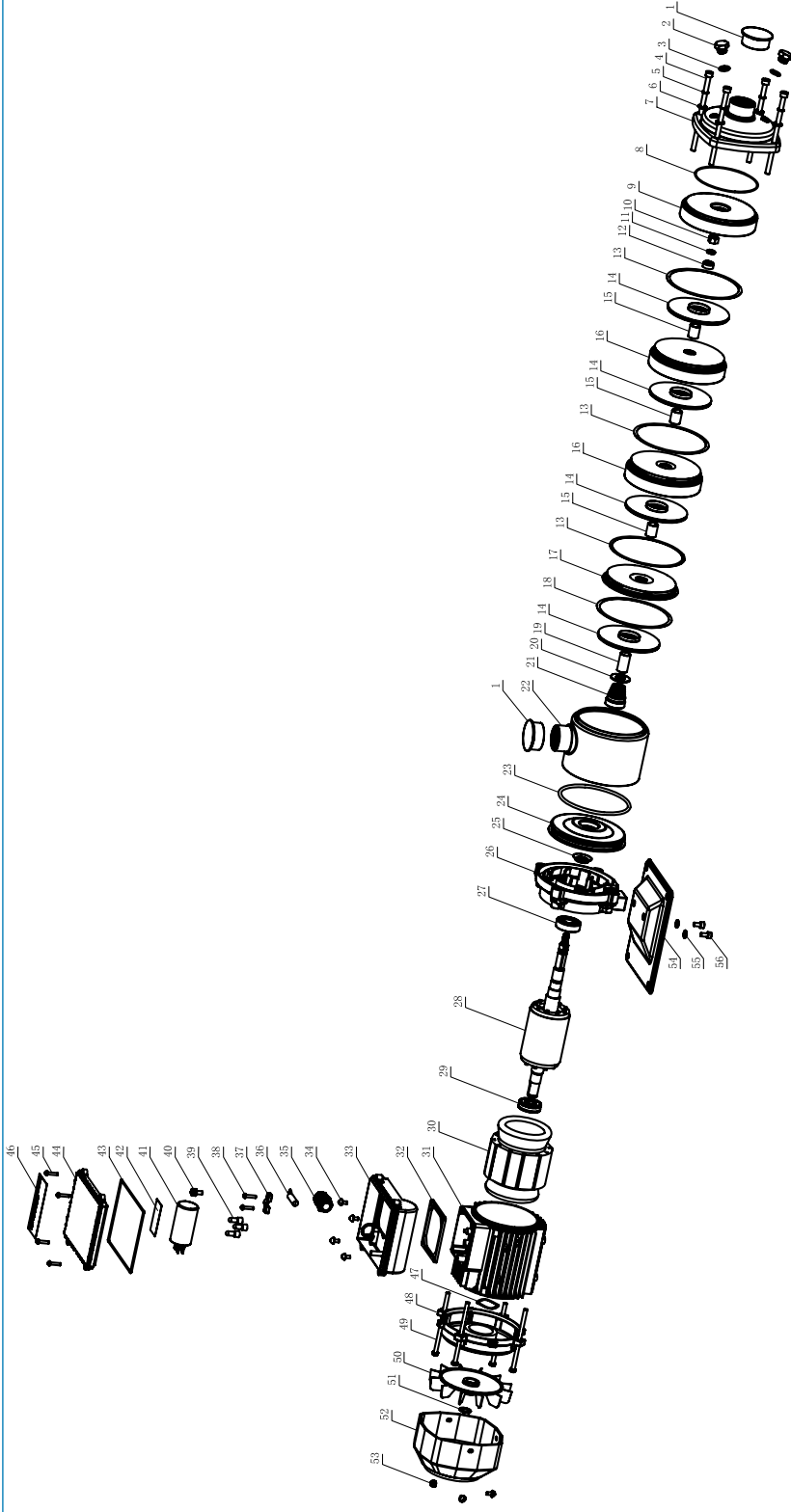

No.	Description	No.	Description	No.	Description	No.	Description	No.	Description
1	Dust cap	12	Impeller Fix Ring	23	O-ring	34	Cross recessed pan head screw and washer assemblies	45	Cross recessed pan head tapping screws
2	Plug	13	Seal gasket	24	Pump Cover	35	Cable Seal Cover	46	Name plate
3	O-ring	14	Impeller	25	Retaining ring	36	Cable	47	The three wave
4	Inside hexagonal bolt	15	long sleeve	26	Front Cover	37	Cable pressing block	48	Back Cover
5	Standard spring washer	16	Middle Section section	27	Bearing	38	Cross recessed pan head tapping screws	49	Hexagon bolt
6	Flat washer	17	Last Diffusor	28	Rotor assembling	39	Terminal	50	Fan
7	Inlet section assembly	18	Seal gasket	29	Bearing	40	Cross recessed pan screw, spring washer and plain washer assemblies	51	Axial spring collar
8	O-ring	19	Long sleeve	30	Stator assembly	41	Capacitor	52	Fan Cover
9	Primary Diffusor	20	Shaft shield ring	31	Motor base	42	Wiring Diagram	53	Cross recessed pan head screw and washer assemblies
10	Locked Nut	21	Mechanical Seal	32	Terminal box pad	43	O-ring	54	Base
11	Standard spring washer	22	Outlet section assembling	33	Bottom part of terminal box	44	Upper part of terminal box	55	Standard spring washer